

# BOEING737MAX- AIR TEMP & VOICE RECORDER PANEL



This manual is intended for Flight Simulator use only and may not be used in any real world aviation application. The authors are not responsible for any errors or omissions.

## FOREWORD

Thank you for your choice; AIR TEMP & VOICE RECORDER board for OVH737MAX is a full scale replica of Boeing 737 Forward Overhead air temp & voice recorder panel, look and functionality are reproduced with high details.

through this hardware you will meet a realism never experienced before in your flight with Flight Simulator.

*Note: This manual contains the latest information at the time of drafting. Due to the continuous evolving of the product some features could be been modified. Eventual later information can be found at CPflight website [www.cpflight.com](http://www.cpflight.com)*

CPflight modules are produced to meet requirements from the hobby market. The use of our products in professional or commercial environments is not permitted without approval of the CPflight management; please contact us at [info@cpflight.com](mailto:info@cpflight.com) if you need to exploit our products in professional or commercial environments.

## IMPORTANT NOTE:

CPflight AIR TEMP & VOICE RECORDER PANEL is an expansion module intended for CPflight daisy chain connection and it require CPflight ELECTRICAL

PANEL to operate. The ELECTRICAL PANEL performs the function of "central unit" for all the other modules that make the overhead. AIR TEMP & VOICE RECORDER PANEL does not use any computer's inputs like usb port ecc or power supply adapter, it connect through the provided 4 pole flat cable to the ELECTRICAL PANEL that is the only module connected to the ethernet.... ELECTRICAL PANEL, all other B737 overhead panels, frame and Back-cover are available on CPflight website.

AIR TEMP & VOICE RECORDER is equipped with:

- Custom high resolution warm white backlighting frontplate
- The only overhead hardware with annunciators pushbutton test
- ZONE TEMP (3), DUAL BLEED, PACK (2), WING BODY OVERHEAT(2), BLEED TRIP OFF(2), AUTO FAIL, OFF SCHED DESCENT, ALTN and MANUAL annunciators
- VOICE RECORDER switch with electromagnetic disengage
- Original APEM LOCK-LOCK switch with white CAP for TRIM AIR, ENGINE BLEED AIR ( LET and RIGHT ) and APU BLEED AIR functions
- Original APEM LOCK-LOCK-LOCK switch with white CAP for L PACK, R PACK and ISOLATION VALVE functions
- AIR TEMP Backlighted Gauge
- DUCT PRESS L & R Backlighted Gauge
- Boeing style BACKLIGHTED knob for AIR TEMP rotary switch
- Boeing style BACKLIGHTED knobs for CONT CAB, FWD CAB and AFT CAB regulation
- Painted 1/4 Turn Original Fastners ( 12 pieces provided )
- Provided with a 4 pole cable for daisy chain interface with the main module ( Boeing737 ELECTRICAL PANEL )
- Compatible with Prosim737 V3, Project Magenta, PMDG737NGX, PMDG737NGX series and iFly737. Time by time could be add new compatibility.

## HOW CONNECT

Connect the DIGITAL AIR TEMP & VOICE RECORDER board to the ELECTRICAL PANEL using the provided 4 pole. Connection is very simple and thanks to a guided insertion key on the connector is not possible to reverse the cable polarity (see red circle in the pictures on the next page). The cable can be connected to any of the of the connectors arranged on ELECTRICAL PANEL.



## CONNECTIONS DIAGRAM

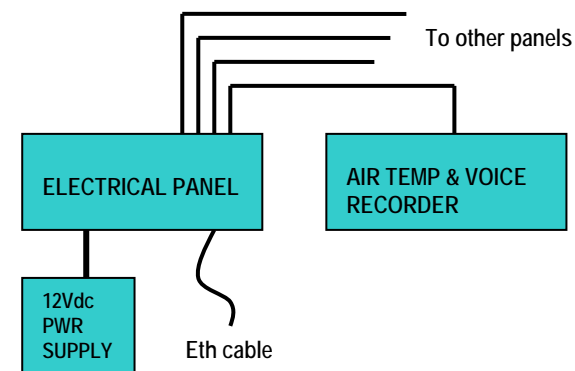

## DIMENSIONS

